

DEVELOPMENT OF A BANK SECURITY SYSTEM USING PROGRAMMABLE LOGIC CONTROLLER (PLC)

Anis Skopak

International Burch University
Bosnia and Herzegovina
anis.skopak@gmail.com

Semir Sakanovic

International Burch University
Bosnia and Herzegovina
symorgh13@gmail.com

Abstract: The aim of this project is to solve the bank security problems (robbery, illegal weapons, and the safety of employees) caused by lack of the security in the banks. This project is divided into two parts which are hardware and software. A kind of bank security system by using Programmable Logic Controller (PLC) was designed, and the automatic control of the bank security system was performed by software. The hardware part is the model of one bank containing two front doors, one door of the vault room, and some sensors. The limit switches, doors and sensors are connected to **Zelio PLC Schneider SR3B261BD**. The PLC controls every signal which is coming from the inputs (Limit switch) to software and display to the outputs (Doors). Using software, Function Block Diagrams (FBD) are programmed to control the traffic light.

Keywords: Programmable Logic Controller, Function Block Diagrams, PLC, FBD

Introduction

This is an era when control and disposition increase, and signal integrity problems are getting more and more severe, and time when design teams are available to solve these problems and design new products in short time. This is an era when Programmable logic control (PLC) is exchanging many other components and devices. There is huge fan of reasons why, here are some of them: they are more practical, simpler, very fast, cooperative, payable, etc. Many successful companies are those that using PLCs overcoming their integrity and implementation problems. In high-speed production, accuracy and correctness are very crucial and one of the most important parameters. By understanding the fundamental principles of guideline and controlling PLCs at the engineering level, every engineer involved in this field process can see the impact of PLCs on the system performance. The main advantage and factor is that PLCs can work on 220V as well as 24V, and we can say that PLCs have huge scope of work. A programmable logic controller (PLC) is an industrial computer used to control and automate complex systems. Programmable logic controllers are a relatively recent development in a process control technology. It is designed for use in an industrial environment, which uses a programmable memory for the integral storage of user-oriented instructions for implementing specific functions such as logic, sequencing, timing, counting, and arithmetic to control through digital or analog inputs and outputs, various types of machines or processes. Programmable logic controllers are used throughout industry to control and monitor a wide range of machines and other movable components and systems. PLC is used to monitor input signals from a variety of input points (input sensors) which report events and conditions occurring in

a controlled process. Programmable logic controllers are typically found in factory type settings. A typical programmable logic controller employs a backplane to serve as the communications bus for interconnecting the PLC processor with the array of individual input/output devices with which the processor interacts in terms of receiving input data for use in executing the control program and transmitting control data for use in controlling the targeted objects. A PLC includes a rack into which a plurality of input/output cards may be placed. A rack includes several slots into which these input/output cards are installed. Each input/output card has a plurality of I/O points. The I/O modules are typically pluggable into respective slots located on a backplane board in the PLC. An I/O bus couples the cards in the slots back to the processor of the programmable logic controller. The slots are coupled together by a main bus which couples any I/O modules plugged into the slots to a central processing unit (CPU). The CPU itself can be located on a card which is pluggable into a dedicated slot on the backplane of the PLC. The particular processor employed in a PLC together with the particular choice of input and output cards installed in the PLC rack are often referred to as the hardware configuration of the programmable logic controller.

The primary aim of this project is to analyze the scope of PLCs, how to solve problems and create efficient algorithms which help solve some particular problem. In this case, that is bank security system and how to solve security problems in the bank.

Programmable logic controller

A programmable logic controller (PLC) is an industrial computer used to control and automate complex systems. Programmable logic controllers are a relatively recent development in a process control technology. It is designed for use in an industrial environment, which uses a programmable memory for the integral storage of user-oriented instructions for implementing specific functions such as logic, sequencing, timing, counting, and arithmetic to control through digital or analog inputs and outputs, various types of machines or processes.

Programmable logic controllers are used throughout industry to control and monitor a wide range of machines and other movable components and systems. PLC is used to monitor input signals from a variety of input points (input sensors) which report events and conditions occurring in a controlled process. Programmable logic controllers are typically found in factory type settings. A typical programmable logic controller employs a backplane to serve as the communications bus for interconnecting the PLC processor with the array of individual input/output devices with which the processor interacts in terms of receiving input data for use in executing the control program and transmitting control data for use in controlling the targeted objects. A PLC includes a rack into which a plurality of input/output cards may be placed. A rack includes several slots into which these input/output cards are installed. Each input/output card has a plurality of I/O points. The I/O modules are typically pluggable into respective slots located on a backplane board in the PLC. An I/O bus couples the cards in the slots back to the processor of the programmable logic controller. The slots are coupled together by a main bus which couples any I/O modules plugged into the slots to a central processing unit (CPU). The CPU itself can be located on a card which is pluggable into a dedicated slot on the backplane of the PLC. The particular processor employed in a PLC together with the particular choice of input and output cards installed in the PLC rack are often referred to as the hardware configuration of the programmable logic controller.

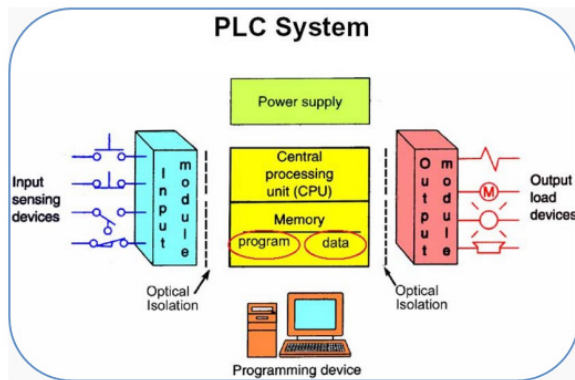

PLC Architecture



PLC Device

The hardware configuration also includes the particular addresses which the I/O cards. Each option module typically has a plurality of input/output points. The option modules are coupled through an interface bus, for example via a backplane, to a main controller having a microprocessor executing a user program. Option modules may also include a microprocessor and a memory containing separate user programs and data directed to a particular operation of the PLC system. During the execution of a stored control program, the PLC's read inputs from the controlled process and, per the logic of the control program, provide outputs to the controlled process. The outputs typically provide analog or binary voltages or "contacts" implemented by solid state switching devices. PLC's are normally constructed in modular fashion to allow them to be easily reconfigured to meet the demands of the particular process being controlled. The processor and I/O circuitry are normally constructed as separate modules that may be inserted in a chassis and connected together through a common backplane using permanent or releasable electrical connectors.

System Hardware

The hardware part of this project is Programmable logic controller (PLC) and a bank security model. SCHNEIDER ZELIO SR3B261BD is the type of PLC used in this project as the processor to control the bank security system. This type of PLC is chosen because of its characteristics which shown optimal for this particular application. The bank security model is constructed to display how this bank security system is running. This bank security model has gates (doors), switches, sensors, speakers, indicator lights, displays. It has three main parts split into two categories. First is modeling, second is wiring system and third is programing the PLC. Modeling and wiring system belong to the first category and programing to the second. The right connection between PLC and bank security model is very important because it can avoid problem or conflict when the program is transferred to the PLC.

The bank security model consists of the following components:

- Six switches
- Four sensors
- Three gates (doors)
- Three speakers
- Three indicator lights
- Two displays

The six switches that this model has are divided into two "Open gate (door) switches", three "Close gate (door) switches" and one "Security Room Switch". The purpose of the two "Open gate (door) switches" is to open gates (doors) in the bank. The purpose of the three "Close gate (door) switches" is to close gates (doors) in the bank, and the one "Security Room Switch" is to turn off the alarm in the bank. In this model we have these four sensors which are presence sensors. We have one presence sensor that opens the main door of the bank, second one is detecting weapon while entering the bank, third one is in vault room and the fourth one is the laser presence sensor which is activated when the bank is not working. Next, we have three doors, two of them are front doors of the bank and one of them is for the vault room. Also, we have three speakers used for alarm system.

One of them is in vault room, second one is located where the weapon presence sensor is, and the third one is when the laser sensor is in "On" state when the bank is not working. The three indicator lights are positioned like the three speakers and they are also activated at the same time as speakers. End at last we have two displays that are placed in front of vault room and in the vault room. These displays are for entering the password while entering or leaving the vault room. Once hardware is designed cabinet box is use to connect PLC with the bank security model. A basic wiring diagram is as shown in Figure 7. The PLC supplied with DC power 24V and then I/O card supplied with DC 24V. The common for input card is 24VDC. Using a smart relay means that ordinary switches (with open or closed positions) can be used in place of two position switches. The switches are identified as **S1** and **S2** in the wiring diagram above. **S1** and **S2** are connected to inputs **I1** and **I2** on the smart relay. The operating principle is as follows: Each time the status of inputs **I1** and **I2** changes, the status of output **Q1** also changes which controls the lamp **L1**, in our case it can be one of the gates. The figure above is just for the illustration purpose only.

Schneider Zelio SR3B261BD 16/10

Smart relays are designed to simplify the electrical wiring of intelligent solutions. A smart relay is very simple to implement. Its flexibility and its high performance allow users to save significant amounts of time and money. A Zelio SR3B261BD is typically digital device using relay on the output. Generally voltage limits is between 19.2 – 30V, and 4mA discrete current input. It has 16 inputs and 10 outputs connected to the 24V DC power supply with the power 0.2W and max current 8A or 5A with conversion error $\pm 5\%$ at 25 °C, and $\pm 6.2\%$ at 55 °C. It has local display on the main side. Number or color scheme lines ≤ 200 with FBD programming and 120 with ladder programming. Response time is 10ms (from state 0 to state 1) for relay output, and 5ms (from state 1 to state 0) for relay output. Ambient air temperature for operation is between -20 °C and +40 °C. Instead of relay we can use also transistors which are more productive and more frequently used in the practice. Relay can handle more current than transistor output but the transistor output is faster than relay because of that there is no mechanical time constant like the relay mechanical contact, also the durability of the transistor output is higher from the number of ON/OFF point of view. One thing to consider is that, most PLCs with transistor outputs, is cheaper than PLC with relay outputs, and of course it has a longer life also it is faster, so it offers more options than a simple relay output. We should always use transistor output cards and put an interface relays to protect them against any damage. In other words, use a transistor output to trigger a relay, and connect the load to the relay. Relay Outputs typically can handle a larger load and either AC or DC signals. Most PLCs are typically 2 amp relays. A typical transistor output is 5 amps. Unless you're running lights or other low current devices, you will require an interposing device, be it solid state relay or mechanical

relay. The greatest advantages of a transistor output are speed and life cycle. They can turn on in 1 ms or less and with no armature or moving parts, will last much longer than a relay. Keep in mind that whether relay or transistor, life cycle will depend on the amount of current required to turn on the output device. The higher the current, the shorter the life cycle and vice versa. It is amazing how many PLC manufacturers offer products with less than adequate output ratings, given the many uses for PLCs. Even with a 2 amp relay output, many applications still require interposing relays. You would think that they would take this into account when designing their products.

System software

The main task is concerning software development to make modules according to the Hardware diagram and model. Zelio Soft 2 is program used to make these modules that are written in Function Block Diagram (FBD).

Function Block Diagram PLC

Function Block Diagrams (FBD) is a graphical language that allows the user to program elements in "blocks". The blocks can then be wired together like electrical circuits. FBD is one of the languages supported by IEC 1131.

A function block diagram is a diagram which describes a function between input variables and output variables. A function is described as a set of elementary blocks. Inputs and outputs of the blocks are wired together with connection lines, or links. Single lines may be used to connect two logical points of the diagram:

- An input variable and an input of a block.
- An output of a block and an input of another block.
- An output of a block and an output variable.

Zelio Soft 2 is a comprehensive multilingual application designed to help us program the Zelio Logic smart relays. There are eight module categories, each displaying a picture and a full description of the characteristics such as power supply, discreet input/output, clock, language, screen keyboard, and reference, which makes them very easy to identify. This program offers a simple way to configure the modules that are written in Ladder Diagram, Function Block Diagram, or both. When programming, we can set a wide range of parameters dealing with counters, winter/summer functions, timers, auxiliary relays, fast counters. We can also set the date format, time zone, and so on. In case of an error alarm, we can define the type of message that will be displayed, when to send a message and who will receive it via telephone or e-mail. We can also enter one or more users that can send control commands. Both the user interface and the simulation languages can be switched into English, Spanish, German, Italian, or French. This program can be downloaded and used free of charge. It is also possible to get this programming solution on a CD from distributors. Zelio Soft 2 can run under all versions of Windows. One of the benefits of this type of PLC is Quick programming. From an intuitive interface, create and modify programs in record time using an extensive number of "drag and drop" pre-programmed functions. Types of languages: Ladder and Function Block Diagram (FBD).

Software of bank security system using Function Block Diagram (FBD)

For better understanding software, FBD is divided into several stages. The first part is used to control two front gates (doors) and weapon presence sensor (detector), second to control vault room, and third to control the alarm system when the bank is not working (non-working hours). More in depth about these stages will be expostulate later on this chapter.

FBD application

There are several block which are controlling this bank security system. First one is for detecting weapon in the bank, second one is for controlling the vault room, and the third one is for controlling the bank when the bank is not working, means the laser presence sensor will be activated on non-working hours. The full system will be described on following papers.

Case I

First case is when the bank is working (working hours) and where there is no weapon detection. So, while entering the bank the "presence sensor" which is located in front of the gate (door) of the bank will be activated and the gate (door) will be opened. After entering the bank the weapon "presence sensor (detector)" will detect if there is any weapon located on the person that entered the bank. If all clean, the person will be able to enter to the main hall of the bank after employee press the "Switch" to open the second gate (door).

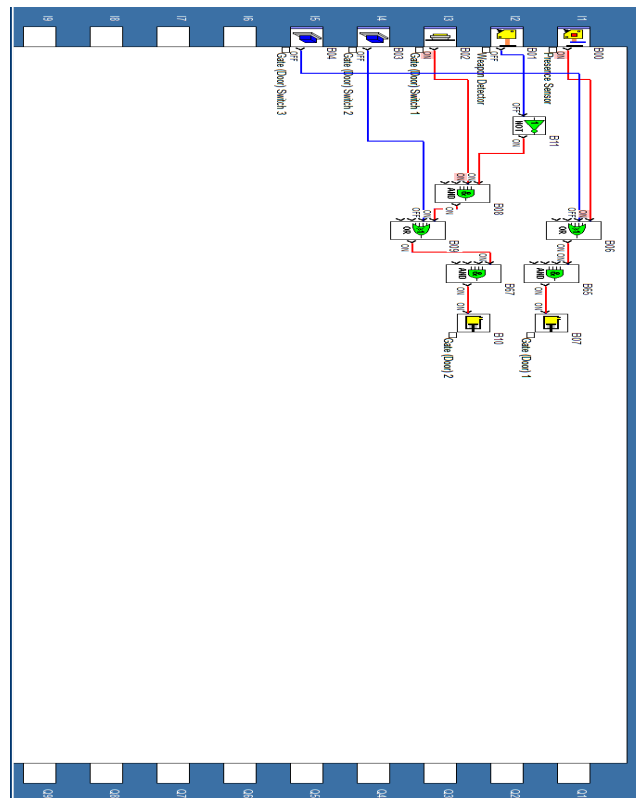

Case I

Case II

Second case is when the bank is working (working hours) but where the weapon detection is detected. So, while entering the bank the “presence sensor” which is located in front of the gate (door) of the bank will be activated and the gate (door) will be opened. After entering the bank the “weapon presence sensor (detector)” will detect if there is any weapon located on the person that entered the bank. In this case the person that entered the bank had weapon and the “alarm” and “indicator light” are in “On” state. All gates are closed, and even if the employee is forced to open the gate by pressing the “Switch”, he will not be able to open because when the alarm is in “On” state, only the “Switch” in the security room can turn “Off” the “alarm” and then the gate (door) can be opened, otherwise when the “alarm” is in “On” state, nothing can be opened till alarm goes to “Off” state. So, the person who has the weapon can only surrender to the police or to the security employee in the bank. After the person decide to surrender, the security guy can turn “On” the “Switch” in the security room and the “alarm” will be in “Off” state. But still employee that is in charge to open gate (door) cannot open the gate (door) until security employee comes and open the gate (door) from the other side. So, to conclude this, only the security employee can switch “Off” the “alarm” and can open the gate (door) after the alarm went to “Off” state from the “On” state.

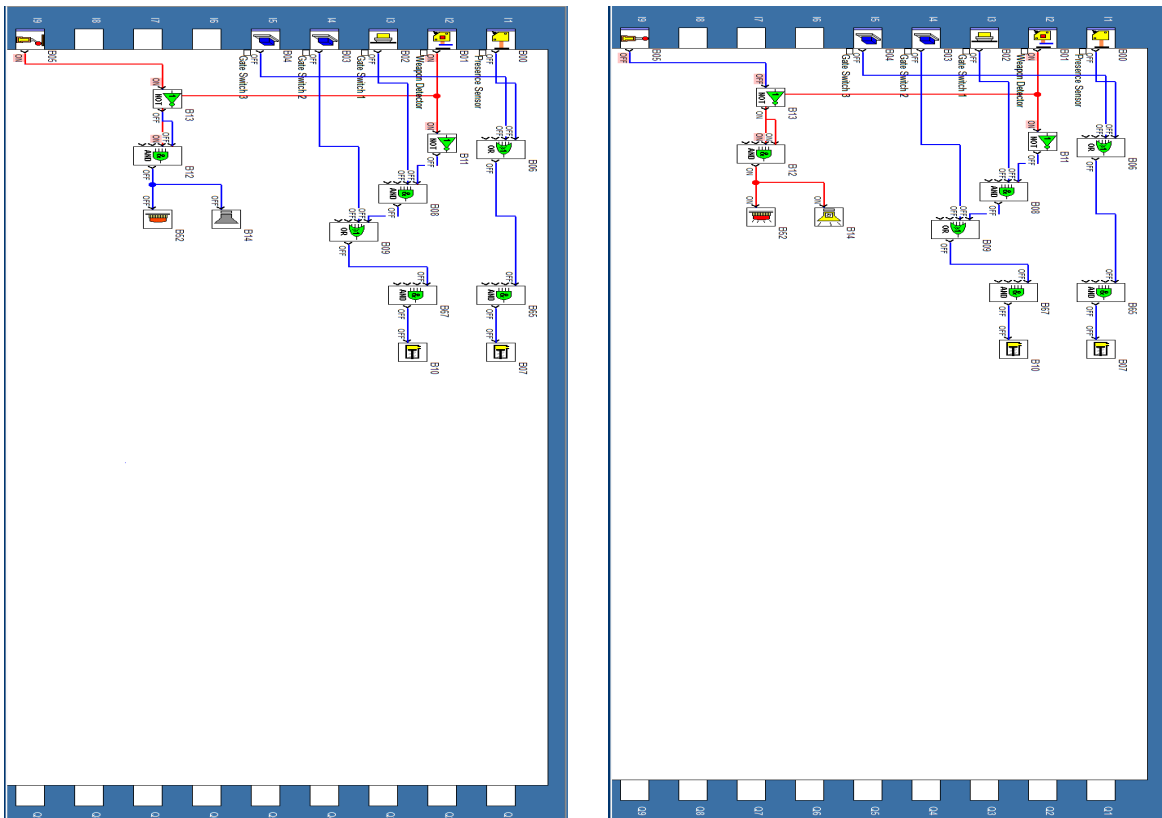

Case II

Case III

Third case is when the bank is working (working hours), but now the bank employee wants to enter to vault room. So, if the bank employee wants to enter to vault room, he/she will need to press the "Switch" for opening the gate (door) of the vault room. After pressing the "Switch" which opens the gate (door) of the vault room, the "display" which is located in front of the vault room will ask the employee to enter the password to be able to enter to vault room. If the employee has entered the right password, the gate (door) of the vault room will open and the employee can enter. After employee has entered into vault room, the "presence sensor" which is located in the vault room will close the gate (door) of the vault room, and the "small alarm" and "indicator light" will be in "On" state to indicate that somebody is in vault room. When employee wants to leave the vault room, he/she will need to press the "Switch" which is located inside the vault room to open the gate (door) of the vault room. When "Switch" is in the "On" state, again employee will need to enter the password, but this time different one, because for the more security, and if employee has entered the right password, the gate (door) of the vault room will open. After employee has left the vault room, the "presence sensor" will detect that there is nobody in vault room and sensor will close gate (door) of the vault room. And the "small alarm" and "indicator light" will go to "Off" state.

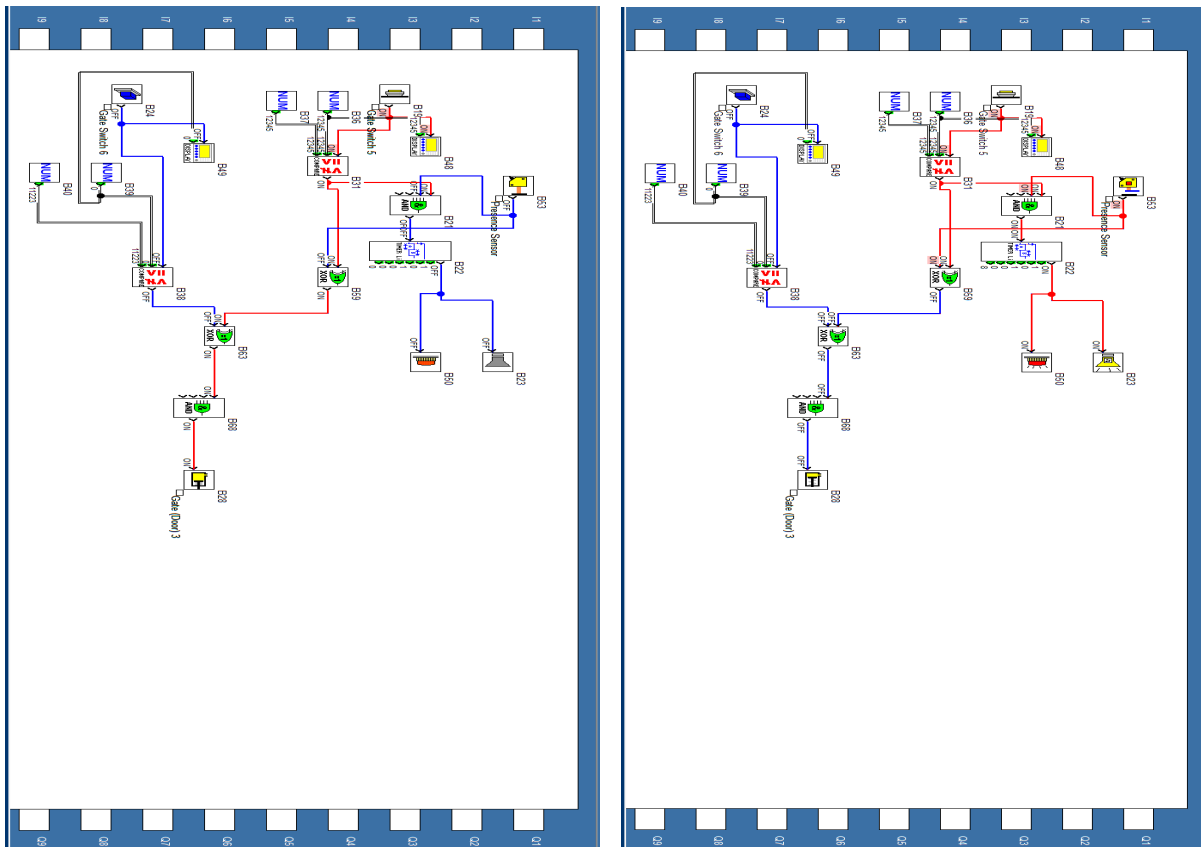

Case III

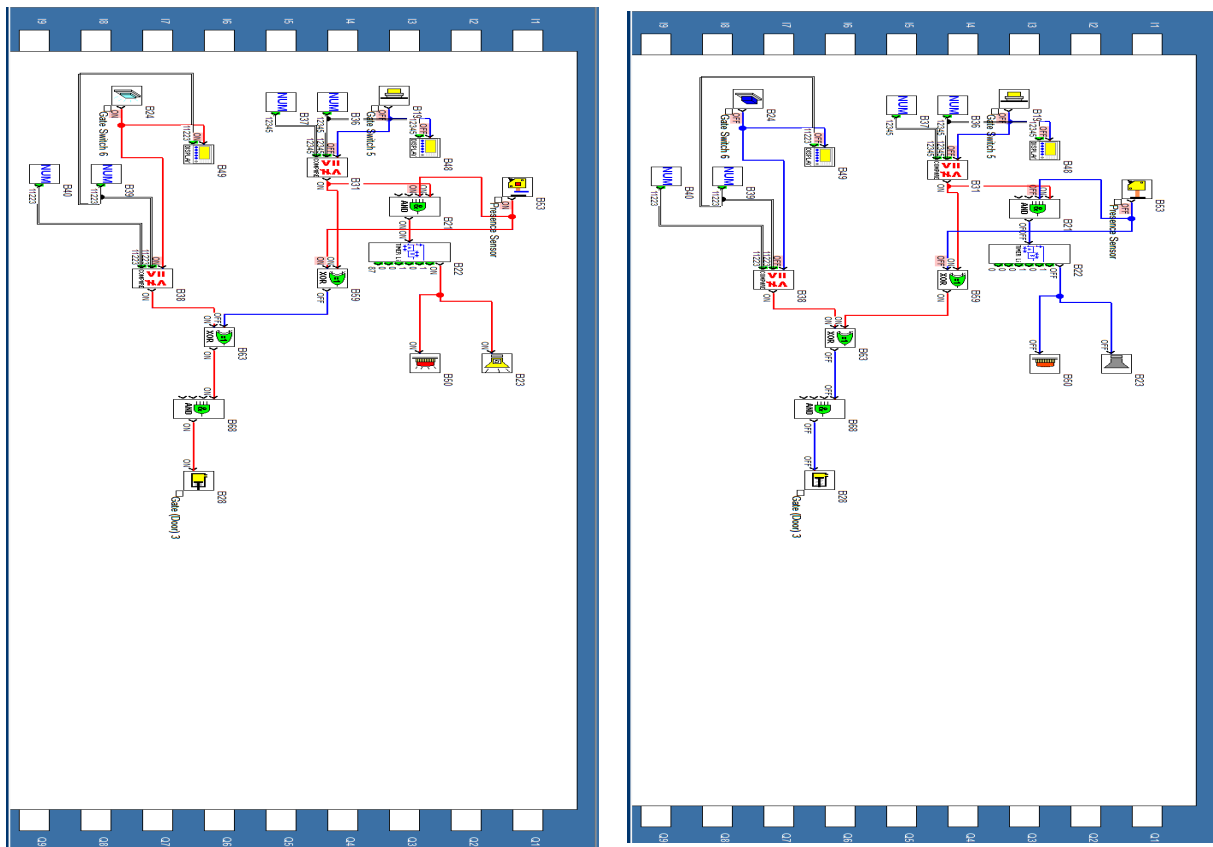

Case III

Case IV

Case four is when the bank is not working (non-working hours). All gates are closed and only the “laser presence sensor” is in “On” state. If nothing happens in the bank, the “laser presence sensor” will go to “Off” state when working hours of the bank start. But, if somebody wants to robber the bank, the “laser” will detect the criminal and the “alarm” and “indicator light” will be activated and they will be in “On” state. None of the gates (doors) can be opened till “alarm” is in “On” state. Again, only person in security room can shut down the “alarm” and only after that gates (doors) can be opened.

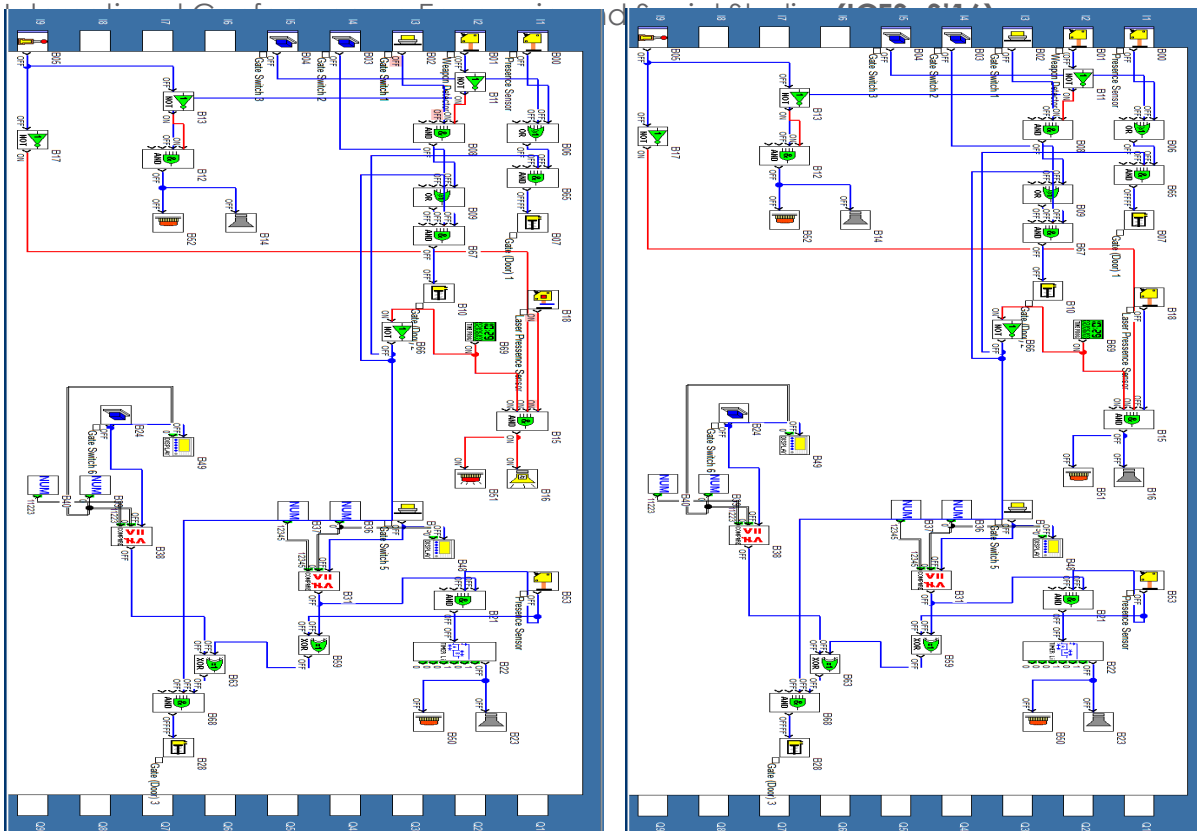

Case IV

Conclusion

This chapter summarized the concept of this thesis. Chapter 2 shows some basic properties of Zelio PLC like function, construction, operation, application etc. Chapter 3 explains very useful method of PLC application in the field. Also in this chapter was construction of the model, wiring system, advantages and disadvantages of the relay and transistor output are mentioned. In Chapter 4, developed application is presented using FBD. An Intelligent Bank Security System that used the PLC to control a security in the bank has been successfully developed. The PLC program (FBD) for implement the two modes of bank security system operation; Working hours Mode and Non-Working hours Mode, have been designed completely and can be operated effectively. All testing has been done successfully, without any error. The aim of this project is to minimize the robbery in banks and it is accomplished successfully. The primary aim of this project is to demonstrate the usefulness of the programmable logic controller (PLC) or programmable controller and how it can be implemented in the field. The usefulness of the built program is that it can be used in various applications and can be extended to have additional features. It is almost impossible to give all possible future work concerning extended built code, but because it has various advantages it can be used to extend the bank security system, airport security system, jewelry stores, other important buildings, etc.

Reference

Daniel Kandrav, *Programmable Automation Technologies*, Industrial Press, 2010 ISBN 978-0-8311-3346-7, Chapter 8 Introduction to Programmable Logic Controllers

E. A. Parr, *Industrial Control Handbook*, Industrial Press Inc., 1999 ISBN 0-8311-3085-7

M. A. Laughton, D. J. Warne (ed), *Electrical Engineer's Reference book*, 16th edition, Newnes, 2003 Chapter 16 Programmable Controller

"The father of invention: Dick Morley looks back on the 40th anniversary of the PLC". *Manufacturing Automation*. 12 September 2008.

Harms, Toni M. & Kinner, Russell H. P.E., *Enhancing PLC Performance with Vision Systems*. 18th Annual ESD/HMI International Programmable Controllers Conference Proceedings, 1989, p. 387-399.

Maher, Michael J. *Real-Time Control and Communications*. 18th Annual ESD/SMI International Programmable Controllers Conference Proceedings, 1989, p. 431-436.

Kinner, Russell H., P.E. *Designing Programmable Controller Application Programs Using More than One Designer*. 14th Annual International Programmable Controllers Conference Proceedings, 1985, p. 97-110.

W. Bolton, *Programmable Logic Controllers*, Fifth Edition, Newnes, 2009 ISBN 978-1-85617-751-1, Chapter 1

Keller, William L Jr. *Grafcet, A Functional Chart for Sequential Processes*, 14th Annual International Programmable Controllers Conference Proceedings, 1984, p. 71-96

Gregory K. McMillan, Douglas M. Considine (ed), *Process/Industrial Instruments and Controls Handbook Fifth Edition*, McGraw-Hill, 1999 ISBN 0-07-012582-1 Section 3 Controllers

Erickson, Kelvin T. (1996). "Programmable logic controllers". *Institute of Electrical and Electronics Engineers*.

Iqbal, S. (2008). "Programmable Logic Controllers (PLCs): Workhorse of Industrial Automation". *IEEE Journal*: 27-31.

Petruzella,, Frank D. (2005). "Programmable logic controllers". *Tata McGraw-Hill Education*.

